

**M
AN
U F
AC
TO**

**LAMP AND SHADE
WITH MARINE**

MATERIALS & TOOLS

NB: The project involves some tools that can be dangerous and require responsible adult supervision.



15 sheets of white A4 paper (preferred thickness for 12 of the sheets: 90 g / alternative: 70 g but this will be less hard-wearing)



1 sheet of corrugated card (c. 30 x 60 cm)



1 electric bulb socket (screw not bayonet preferred) with switch (new or recycled).
*** to be handled by an adult only**



1 very low-wattage LED bulb (to avoid burning the paper)
*** to be handled by an adult only**



Optional: 6 clothes pegs to hold components in place when glueing.



1 x 30 cm ruler



1 pair of scissors and/or 1 cutter
*** to be handled by an adult only**



Glue* in tube or liquid form. Home-made glue may be used: use rice flour, cornflour or a mix of flour and sugar.



1 pencil & 1 black felt-tipped pen

***HOME-MADE GLUE RECIPES**

For the strongest fix: use rice flour or cornflour

- 1 part rice flour or cornflour
- 1 part water

Alternative: use flour and sugar

- 1 cup of flour
- 1 soup spoon of sugar
- 1 glass of water

To make the glue: Pour all ingredients into a saucepan. Warm over a gentle heat until the paste is smooth and thick. Allow to cool. This glue can be used for paper, card, fabric or small objects. It will keep for 2 or 3 days in the refrigerator or in a sealed container.

FOR YOUR PERSONALISED DESIGN (optional)

- A piece of fabric or other supple material (to sheathe the rings, as required) - 20 x 60 cm
- Paint, ink, coloured crayons (for the lampshade)
- Sequins, glitter, cut-out paper shapes (for shadow-play), dried leaves or other small motifs for sticking.
- Paint brush or old toothbrush (if your design involves painted motifs).

BEFORE YOU BEGIN (optional)

- **For a personalised design, be clear how your object will look before you start, so that you can prepare your materials in advance and know when you will need them.**

Collage decoration for the lampshade, pre-assembly: you can glue decorative motifs flat on each half of the lampshade (see below) before assembling. Use cut-out and/or coloured paper shapes, dried leaves etc. Glue everything flat, in the recommended areas for decoration (see Annexes), keeping the structural folds clear.

Painted decoration for the lampshade, after assembly: spatter paint or ink using a toothbrush or paint brush, paint sprayer etc.

Rings (before glueing inside the lampshade): the rings can be sheathed in fabric or decorative paper, painted or left as plain cardboard, according to your design.

- **Familiarise yourself with the patterns, templates and visuals in the Annexes:**

The lampshade is made from two large sheets of paper (each assembled from 6 pieces of A4) and two cardboard rings.

Annexes:

- Lampshade pattern and numbered grid template
- Visual of recommended areas for decoration
- Ring templates
- Lampshade visuals

M
AN

ASSEMBLY

1. PREPARE THE LAMPSHADE AND GRID TEMPLATE

Prepare the 2 halves of the lampshade:

- Take 12 pieces of A4 paper and mark a 1 cm margin around each piece using a ruler and pencil. Two points along each edge are all you need – if you draw lines they may show through the lampshade when it's assembled and lit.

- Apply glue to the 1 cm margin around 6 pieces of A4 paper and stick them edge to edge, vertically (in 'portrait' format), overlapping the margins to form a rectangular sheet of paper, 3 sheets wide and 2 sheets deep (see the lampshade pattern and grid template in the Annexes).

- Repeat with another 6 pieces of A4 paper, to make a second large sheet.

Prepare the grid template:

- Take a single A4 sheet and fold it in half along its length, then fold each of the two long edges inwards to touch the central fold. Open out the sheet: the folds mark out four 'columns'. Do the same across the width of the sheet. You will obtain a sheet divided into 16 equal rectangles.

- Retrace each fold with a ruler and a black felt-tipped pen: this will allow you to see the lines showing through when you place the first large sheet of paper (above) over the grid template.

- Number each square on the grid template, vertically (see Annexes). Number the squares from left to right - A1, A2, A3, A4 across the top row, then B1 to B4 left to right across the second row, and so on down to D4 in the bottom right-hand corner of your grid.

2. DRAW AND CUT OUT THE LAMPSHADE (2 HALVES)

For the lampshade silhouette:

- Refer to the lampshade pattern in the Annexes, as drawn over the red squares on the numbered grid template.

- Place your grid template underneath the first sheet of 6 pieces of A4 paper (begin at sheet 1 as marked on the lampshade pattern in the Annexes). Referring to the lampshade pattern, use a pencil to trace the outline of the lampshade, taking the numbered grid template as your guide. Repeat for each sheet (numbered 2 to 6 in grey on the lampshade pattern). Leave the triangle shapes for the moment – they will be drawn later. For the top and bottom edges of the lampshade, mark each point as a dot within the appropriate square, then join them up using a ruler.

- Trace the 1 cm margins along the left- and right-hand edges of the lampshade silhouette. These will be glued and stuck when the two halves of the lampshade are assembled later.

- Repeat on the second large sheet of 6 pieces of A4 paper, to draw the second half of the lampshade.

For the triangular vents:

- There are four triangular vents in each half of the lampshade: two small ones on the top edge, and two large ones on the bottom edge. Trace both sizes onto a fresh piece of paper and mark them with a letter S (small) or L (large) so that you can identify them easily.

- Cut out both triangles and use these as your outline to draw two more. On both halves of the lampshade, place and trace the triangles symmetrically either side of the central, vertical axis, using the lampshade pattern and numbered grid template in the Annexes as your guide.

Cut out both halves of the lampshade, but do NOT cut out the triangular vents.

3. PERSONALISE YOUR DESIGN (OPTIONAL)

Decorate both halves of the lampshade as desired:

- Glue your decorative motifs (paper cut-outs, coloured paper shapes, dried leaves etc.) to the inside surface of each half of the lampshade, or colour the two halves while flat, prior to assembly. Refer to the visual in the Annexes for the recommended areas for decoration, so that you leave the structural folds clear. Refer to the visuals of the finished lampshade for ideas.

4. PRE-ASSEMBLE THE LAMPSHADE

- Pinch-fold the triangular vents to make it easier to stick them later. Pinch the folds inwards, top and bottom, on each half of the lampshade.

- Use an eraser to remove any traces of pencil markings on both halves of the lampshade.

- Apply glue to the 1 cm margin along the left and right sides of both halves of the lampshade.

- Place the two halves of the lampshade together, one top of the other (glued edges on the insides) making sure that the small triangular vents are positioned at the top in each case, and the large vents at the bottom.

- Press firmly along the left and right-hand edges with your fingers.

- The two sides may not have been stuck together very precisely: adjust the edges by cutting away any overlap with scissors.

M
AN

U I F

5. SHAPE THE LAMPSHADE IN 3D

- Apply glue to the outer surface of the triangular vents (top and bottom).
- Pinch-fold each triangle inwards and hold firmly until the glue has taken (you can use clothes pegs for this).

Final shaping

- Don't be afraid to manipulate the paper into its final shape: slide your hands around the inside of the lampshade to push it outwards and give it its finished form. Refer to the visual if necessary.

6. DRAW AND CUT OUT THE RINGS

- Refer to the ring templates in the Annexes.
- On the corrugated cardboard sheet, trace the outline of the big ring (at the bottom of the lampshade), then the small ring (with the central 'H' bar). Begin by tracing a rectangle, then use the measurements on the template pattern to draw the rounded corners for the final, oval shape. Trace the inner lines of the oval in the same way. (You can use the edge of an upturned bowl to help draw the rounded corners).
- Cut out both 'rings' (ovals) with scissors or a paper cutter.

7. SHEATHE THE RINGS

You can sheathe the rings with fabric or decorative paper, paint them or leave them as plain cardboard, according to your design.

- Bottom ring (the bigger of the two): Take a piece of fabric slightly bigger than the ring (18 x 30 cm) and cut out the ring shape leaving a margin of 1 cm all around the edge. Cut away the holes inside the oval, leaving a 1cm margin here too. Apply glue to one side of the ring and place it, glued side up, on the reverse side of the fabric or decorative paper, taking care to leave the 1 cm margin free all around. Smooth the fabric or paper to remove wrinkles and air bubbles. Cut slits into the fabric at the rounded corners (stop 2mm from the edge of the cardboard), so that it can be folded without wrinkles. Fold the fabric over onto the glued surface of the ring.
- Top ring (the smaller of the two, with the 'H' bar): Take a piece of fabric slightly bigger than the ring (12 x 24 cm) and cut out the ring shape leaving a margin of 1 cm all around the edge. Cut away the holes inside the oval, and the small hole in the H bar (where the socket will be fixed). Glue the ring and stick the fabric as for the bottom ring.



8. FIX THE RINGS TO THE LAMPSHADE

IMPORTANT: Start with the big, bottom ring. This will allow you to put your hand up inside the lampshade to stick the smaller, top ring. The big, bottom ring will be stuck to the bottom of the lampshade (inside the big opening with the small triangular vents). Do this standing up so that you can position the ring more easily. Don't be afraid to push the lampshade out of shape if you need to, to stick it firmly to the ring.

- Apply a generous layer of glue to the large ring.
- Press the glued ring inside the big, bottom opening in the lampshade. Slip your hand inside the lampshade to press the edges of the paper onto the ring, making sure from the outside that the paper sticks to the underside of the ring. Press firmly. One edge may come unstuck when you stick the other. Pass your hand back and forth quickly to stick all edges down. Hold the ring in place with clothes pegs if necessary.
- Once the first ring is stuck, repeat for the second, smaller ring inside the top opening.
- Cut away any excess paper around the margin each ring, using scissors or a paper cutter, once the glue has taken.

9. FIX THE ELECTRIC CABLE AND BULB SOCKET

- In the smaller, top ring, make a small slit with a paper cutter from one edge of the H bar to the central hole. Push the electric cable through the slit into the hole and fix it with a dab of glue as required.

10. PERSONALISATION (OPTIONAL, FOR PAINTED DESIGNS)

- After assembling the lampshade: spatter paint or ink with a toothbrush or paintbrush, or a paint sprayer.

M
A N
U F

ANNEXES

Lampshade pattern and numbered grid template

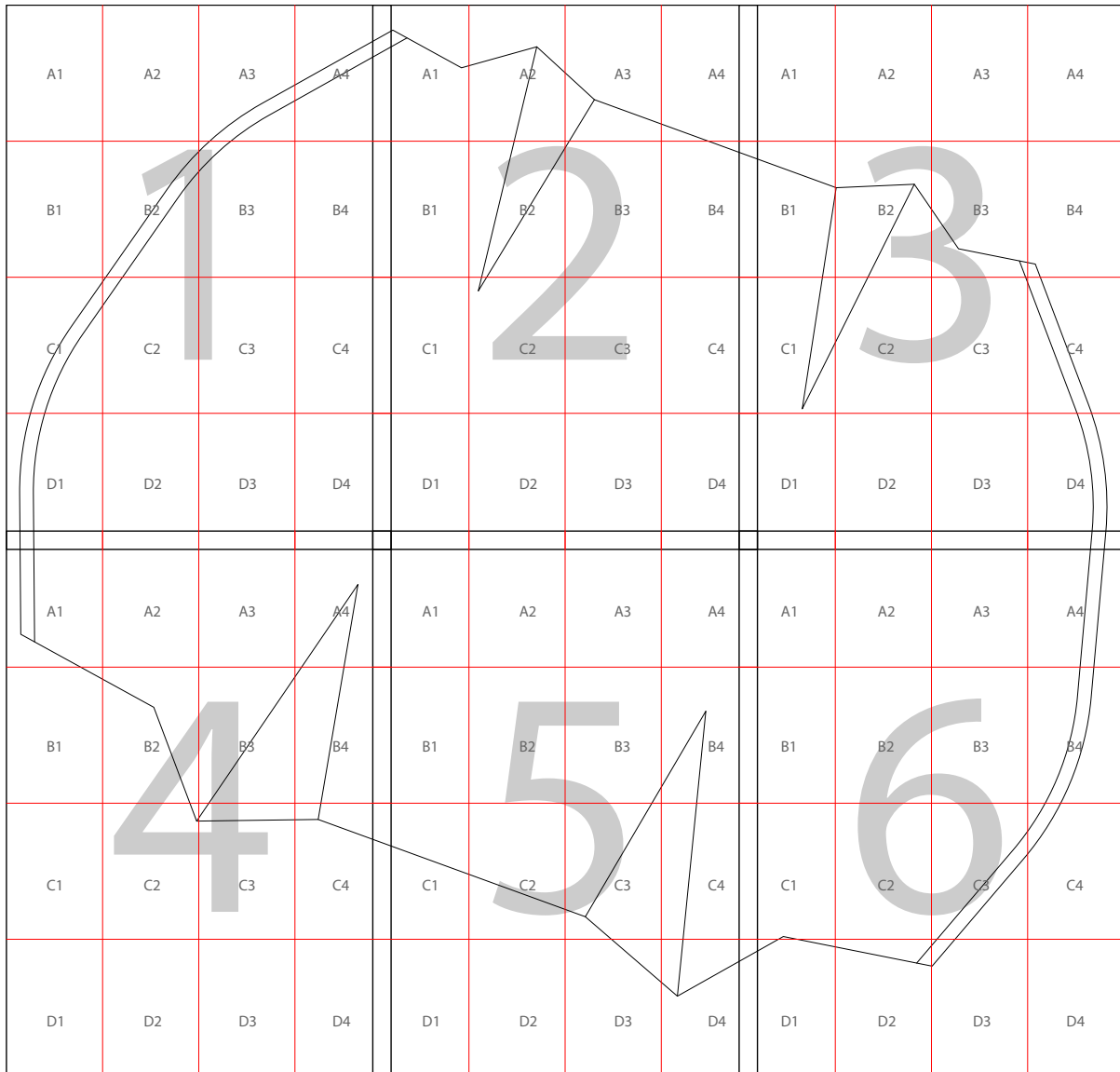

ANNEXES

Recommended areas for decoration

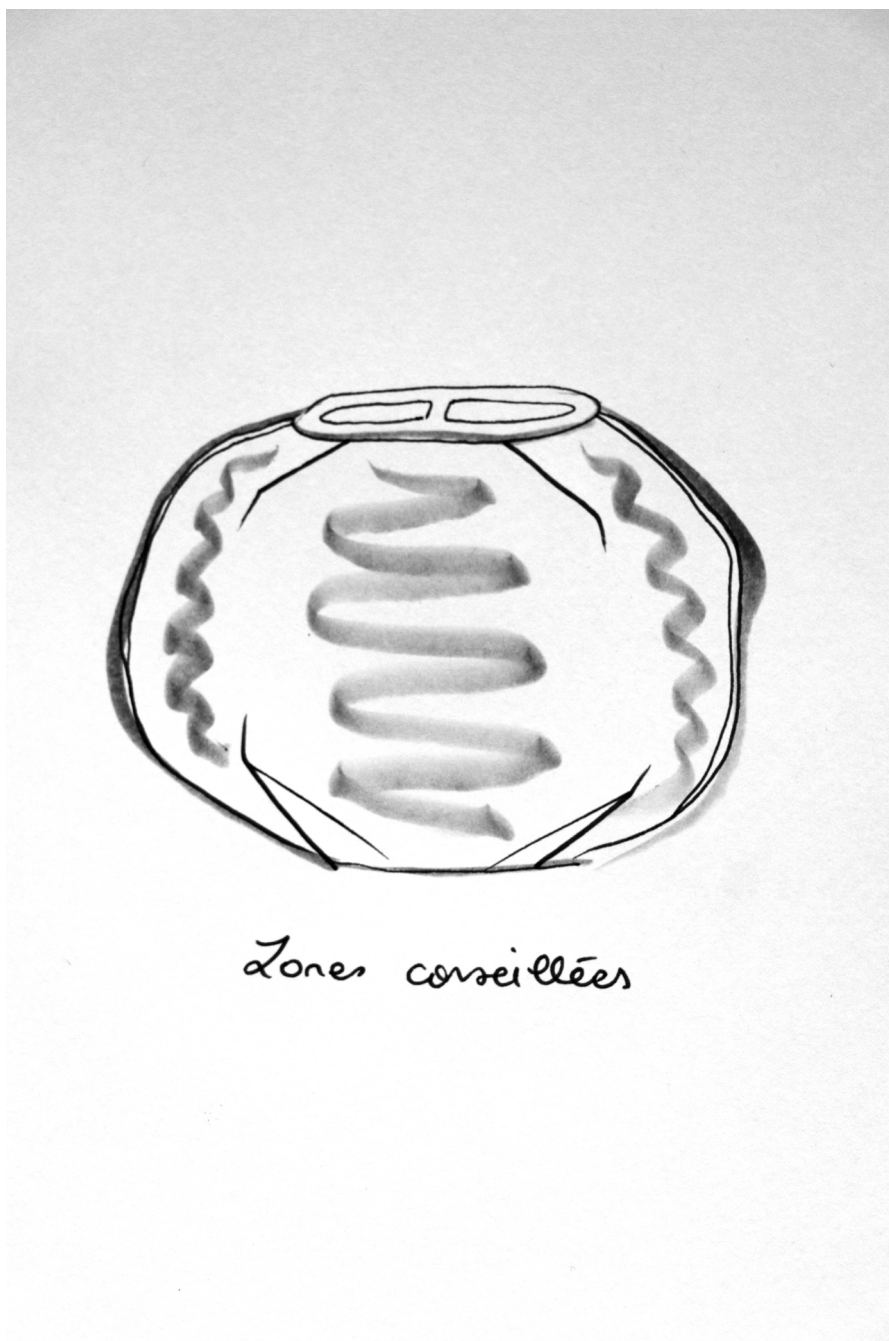

Zone conseillées = Recommended areas

ANNEXES

Small (top) ring template with 'H' bar

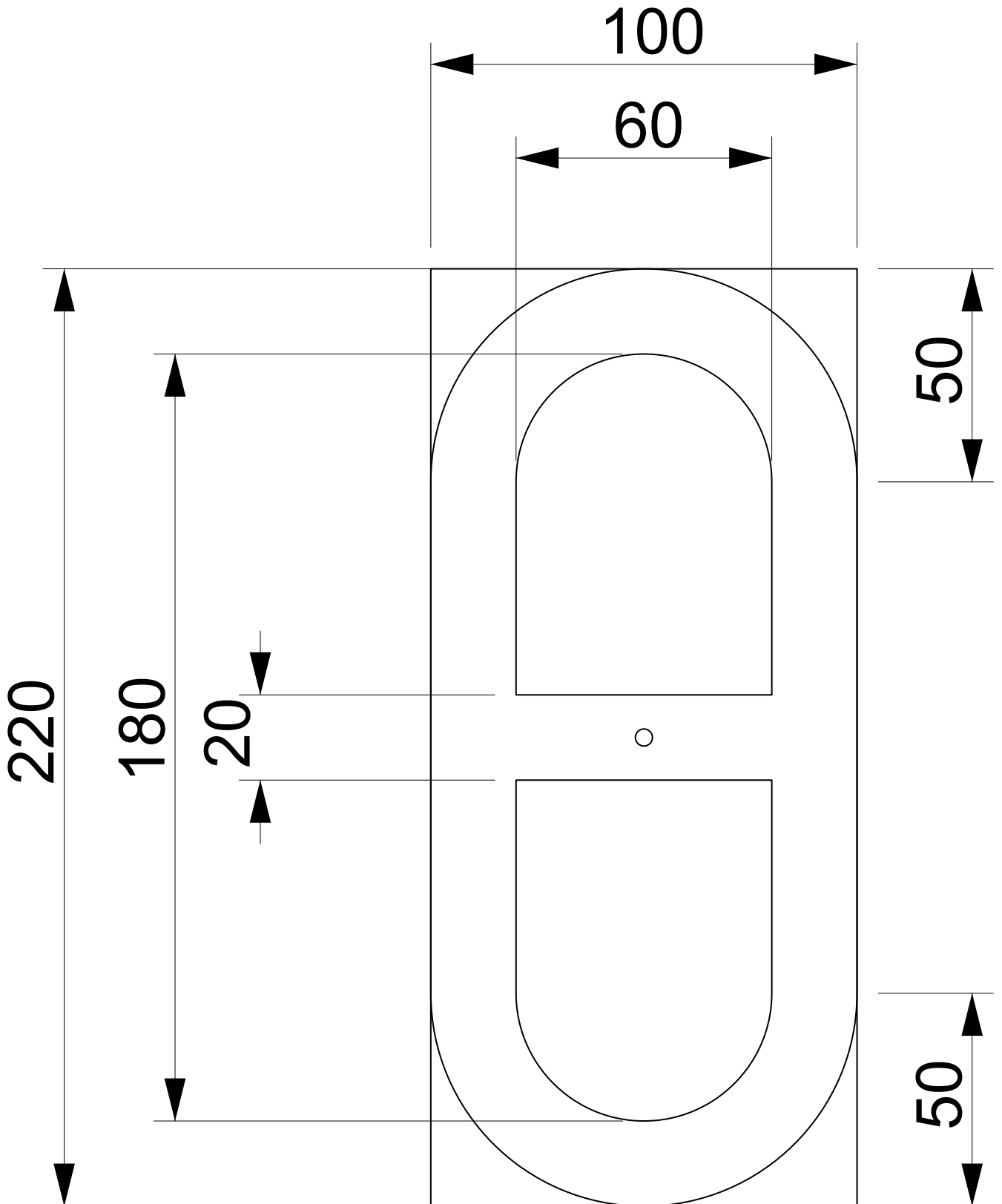

ANNEXES

Large (bottom) ring template

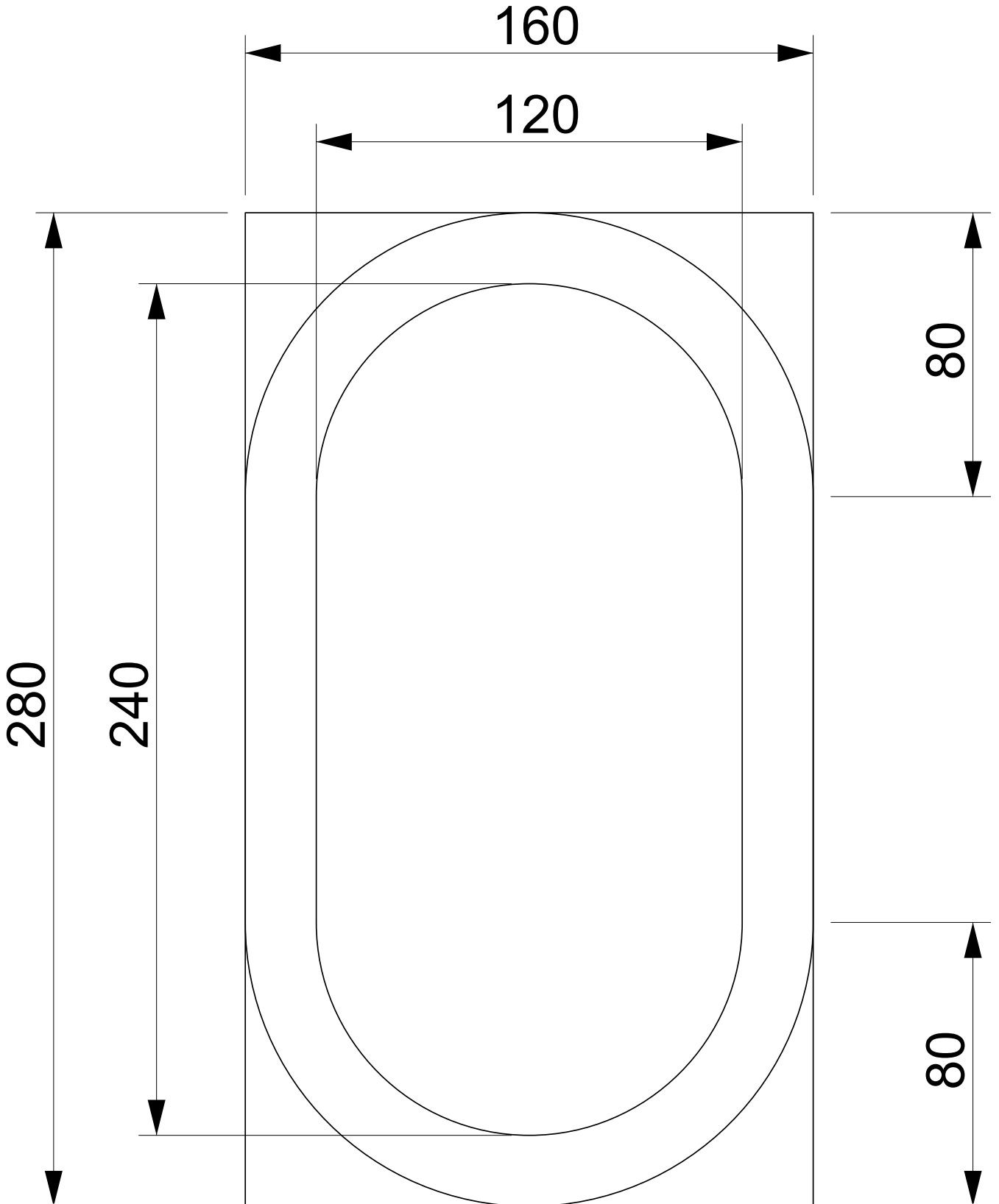

ANNEXES

Lampshade visuals

